

FR SST

FR 0 / FR 1 / FR 2 / FR 3

The retaining brake eliminates door slams. Manufactured in stainless steel, this tool is designed to work under the most unfavourable weather conditions. It operates in the last 10°, thus ensuring the complete closing of the door. Adjustable closing speed in between 1 and 10 seconds (G models).

SST MODEL

Outside materials

- cylindrical body: anodized aluminum.
- other external components: stainless steel AISI 304 (polished)
- hook: stainless steel AISI 304 (polished)
- pins: steel
- wheel: synthetic rubber

Inside materials

- hydraulic oil
- inner spring: special

Performance

- mechanism: hydraulic system
- closing system: possibility of fixed or adjustable closing speed (G models)

ALL SST MODEL

Outside materials

- cylindrical body: anodized aluminum.
- other external components: stainless steel AISI 304 (polished)
- hook: stainless steel AISI 304 (polished)
- pins: stainless steel AISI 304 (polished)
- wheel: synthetic rubber

Inside materials

- hydraulic oil
- inner spring: special

Performance

- mechanism: hydraulic system
- closing system: possibility of fixed or adjustable closing speed (G models)

Proper installation

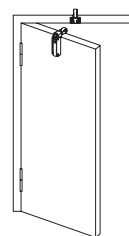

Easy speed adjustment (G models)

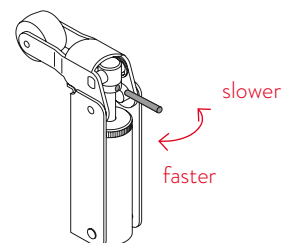

FR 0 (G) FR 1 (G)

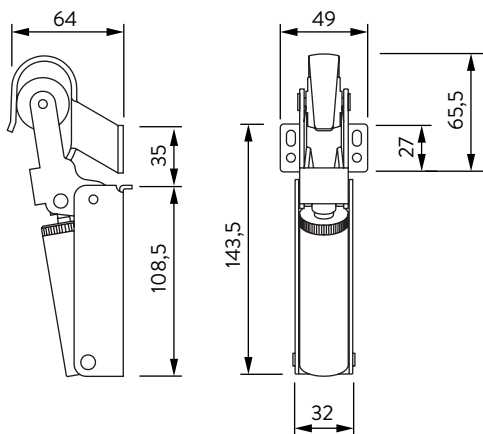
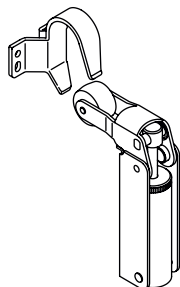

	FR 0 FR 0 G	FR 1 FR 1 G
--	----------------	----------------

Strength (N)	30	60
Door width (cm)	75	85
Door weight (kg)	15	40

FR 2 (G) FR 3 (G)

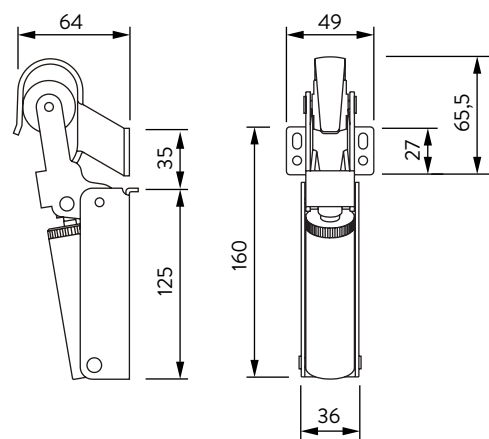
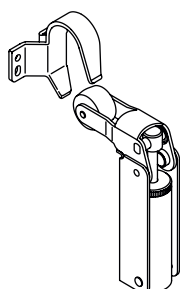

	FR 2 FR 2 G	FR 3 FR 3 G
--	----------------	----------------

Strength (N)	80	115
Door width (cm)	110	125
Door weight (kg)	80	100